

AirROC D35 SH

Surface drill rig for dimensional stone and special application

Hole diameter: 89–115 mm (3.5"–4.5")





A compact “Little Power House” for DTH drilling

AirROC D35SH is a semi hydraulic DTH drill rig from Epiroc. This compact, high reliable drill rig is a move towards graduating pneumatic drill users for a more efficient but simple hydraulic concept. This would give clear visible benefits of lower fuel consumption and high productivity. This is an ideal choice for DTH drilling as it fits in with production, development, and hole matching application drilling in dimensional stone quarries and special applications.

The AirROC D35SH is a down the hole drill rig with the entire function powered by hydraulic except the DTH hammer. The drill has onboard diesel engine which is a source of power for the hydraulic system.

Main functions including tramming, positioning, feed, and rotation unit are hydraulically powered.

⊕ Main benefits

- » Tailor made for dimension stone drilling
- » Quick positioning time and low fuel consumption
- » Excellent hole quality
- » Horizontal drilling with minimum ground clearance
- » Dual rotation unit for two side drilling

Compact solution for maximum performance

The AirROC D35 SH drill rig from Epiroc is straight forward and packaged with single stage portable compressor and Down-The-Hole hammer. With the compact and simple AirROC D35 SH, benefitted with low fuel consumption, ground level serviceability, and better performance.



+ Optimum performance

AirROC D35 SH is powered by the reliable on-board 50 HP Mahindra diesel engine. The hydraulic system is well synchronized to meet the demand of this drill.

It has a heavy-duty feed mechanism which can generate tractive pull of 20 kN along with a powerful dual output rotation unit which provides high rotation torque at both end to tackle challenging rock formations with more accuracy for hole matching with the new drill steel supports.

+ Easy to maneuver

On-board engine with low fuel consumption to tram the rig easily in the quarry without additional equipment.

The rig's low center of gravity and high ground clearance provides smooth mobility over the most challenging terrain.

+ Easy operation and easy maintenance

Ensure operator's comfort and safety with ergonomic controls and safety enhancing features. Simple design, empowers the maintenance crew to trouble shoot quickly and easily.



Epiroc service

Even the best equipment needs to be serviced regularly to make sure it sustains peak performance. An Epiroc service solution offers peace of mind, maximizing availability and performance throughout the lifetime of your equipment. We focus on safety, productivity and reliability.

By combining genuine parts and an Epiroc service from our certified technicians, we safeguard your productivity – wherever you are.

Technical specifications

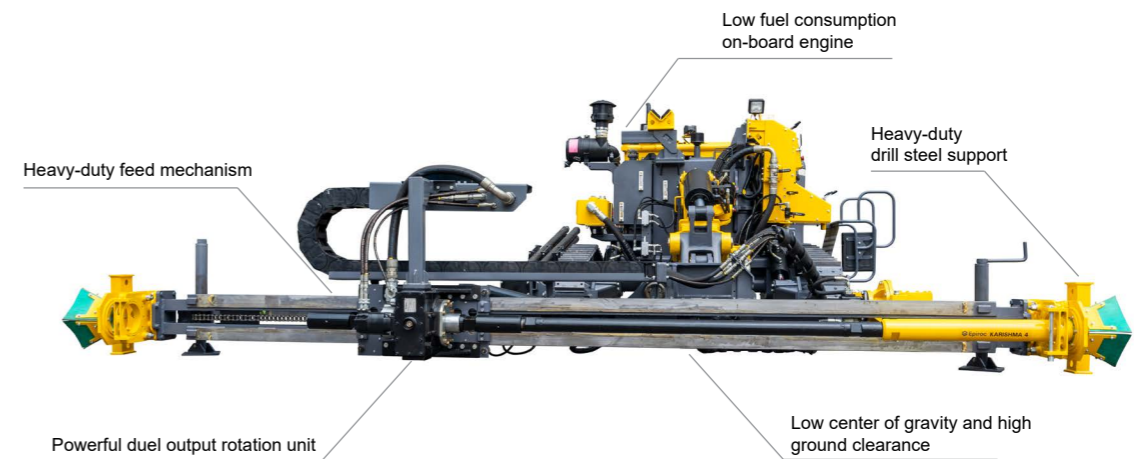

Main components

- Engine is on-board to power hydraulic system
- Diesel engine for tramping and positioning
- Fixed boom system
- Track frames with single grouser pads and hydraulic track oscillation
- Hydraulically operated dual speed traction
- Steel feed beam and feed extension
- Hydraulic operation feed and rotation unit
- Chain feed system
- Towing hook
- Work lights (3 nos)

General

	Metric	US
Maximum drill diameter	89-115 mm	3.5-4.5 in
Pipe diameter	76 mm x 3 000 mm	3 in x 12 in

Feed system

Type	Hydraulic-motor driven chain feed with hose guide	
Feed extension	1 200 mm	472 in
Feed rate	0.4 m/s	78.74 ft/min
Maximum feed rate	0.6 m/s	118 ft/min
Maximum feed force	12 kN	2 697 lbf
Total length	5 108 mm	201 in
Travel length	4 200 mm	165.3 in
Maximum tractive pull,	20 kN	4 496 lbf

Rotary head

Type	Hydraulic	
Connection thread	2 3/8 in API	
Maximum rpm	70	
Maximum torque, drilling/ breaking	1 205 Nm (888 lbf)	
Suitable for DTH-hammer	Hammer suitable to drill 89 mm-115 mm (3.5 in-4.5 in) dia hole	

Hydraulic system

Hydraulic oil cooler		
Maximum ambient temperature	50°C	122°F
Pumps		
Gear pump 3	57/57/26 L/min (2/2/1 cfm)	
Return and drainage filter		
Filtration rate	10 µm	

Compressor (portable)

Compressor pressure	10.5 bar-12 bar	150 psi-175 psi
FAD	189 L/s-260 L/s	400 cfm-550 cfm

Engine

Mahindra 4-cylinder diesel engine, water cooled	Metric	US
Power rating at 2 600 rpm	38 kW	50 hp

Capacities

Hydraulic oil tank	135 l	35 gal
Hydraulic system (total)	180 l	49 gal
Diesel engine oil	8.5 l	2.2 gal
Diesel engine, coolant	16 l	4.2 gal
Diesel engine, fuel tank	36 l	9.5 gal
Traction gear (each)	1 l	0.26 gal
Lubrication tank	7 l	1.85 gal
Water tank	110 l	29 gal

Undercarriage

Track oscillation	± 10 deg	
Ground clearance	284 mm	11.2 in
Maximum traction force	38 kN	8 542 lbf
Hill climbing ability	26° (without compressor)	
Track speed	High	2.8 km/h
	Low	1.8 km/h
		1.74 mph
		0.62 mph

Electrical system

Voltage	12 V	
Batteries	1	
Alternator	14 V	
Work lights, front	2 x 35 W	
Work lights, rear	1 x 35 W	

Technical specifications

Transport dimensions

Tramming position		Metric	US
Height		2 624 mm	103.3 in
Length		6 351 mm	250 in
Transportation position		Metric	US
Height		2 624 mm	103.3 in
Length		6 351 mm	250 in
Width		2 546 mm	100 in

Other dimensions and weight

	Metric	US
Feed height	5 487 mm	216 in
Weight		
Standard unit excluding all options and drill steel	5 500 kg	1 2125 lb
Standard unit excluding all options and drill steel	6 000 kg	1 3227 lb

Transport dimension (mm)

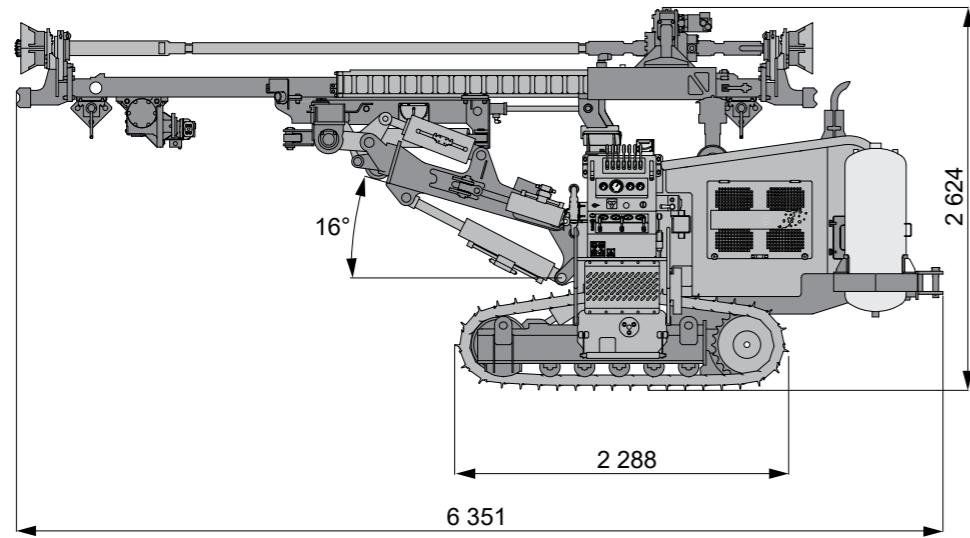

Feed swing

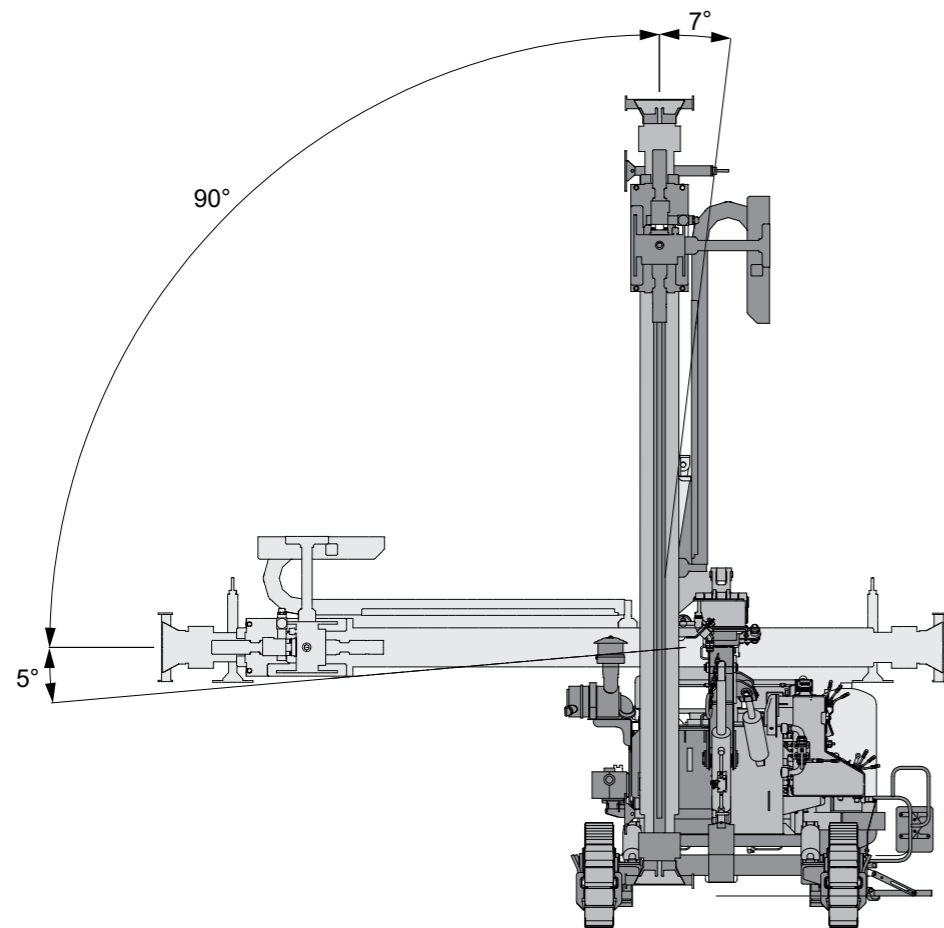

Vertical reach (mm)

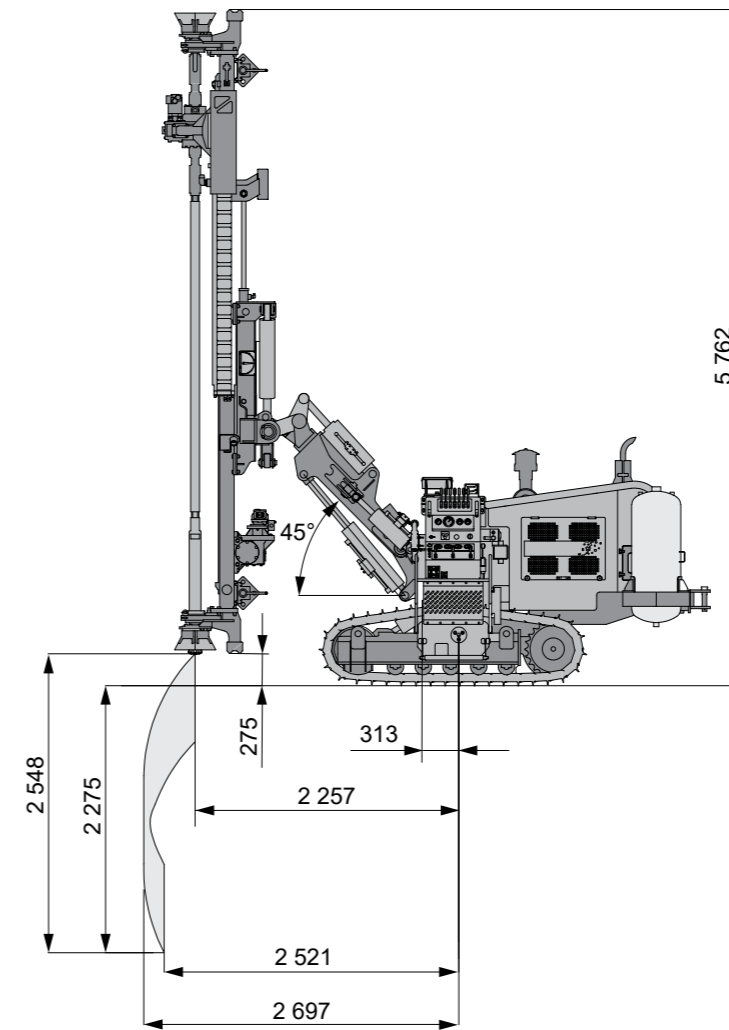

Vertical coverage area (mm)

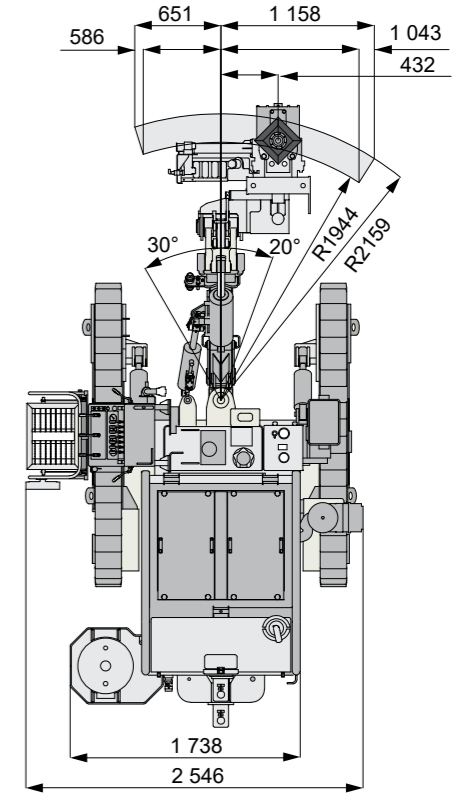

Horizontal reach (mm)

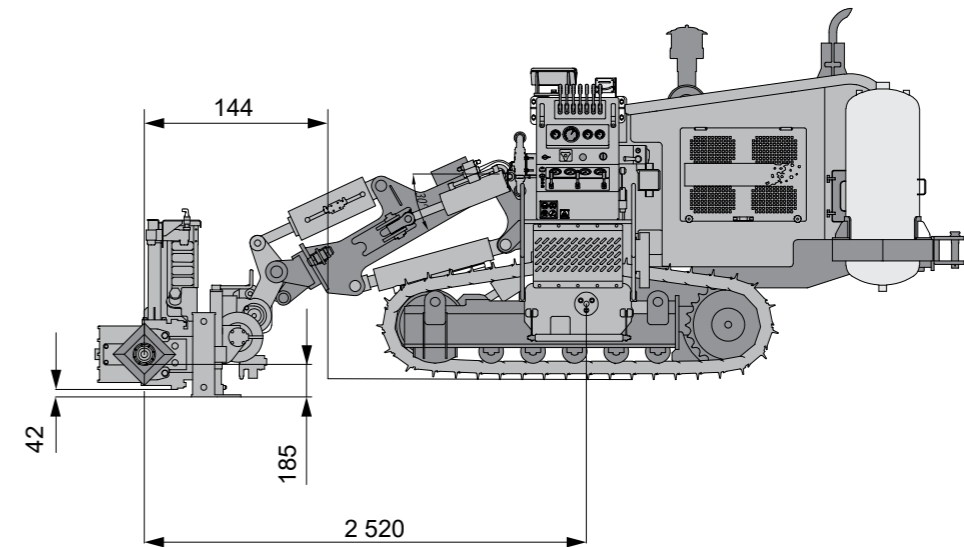

United in performance. Inspired by innovation.

Performance unites us, innovation inspires us, and commitment drives us to keep moving forward. Count on Epiroc to deliver the solutions you need to succeed today and the technology to lead tomorrow.

[epiroc.com](https://www.epiroc.com)

